

BALL VALVES INTEC

Grid unit

INTEC 20, DN15 - DN65

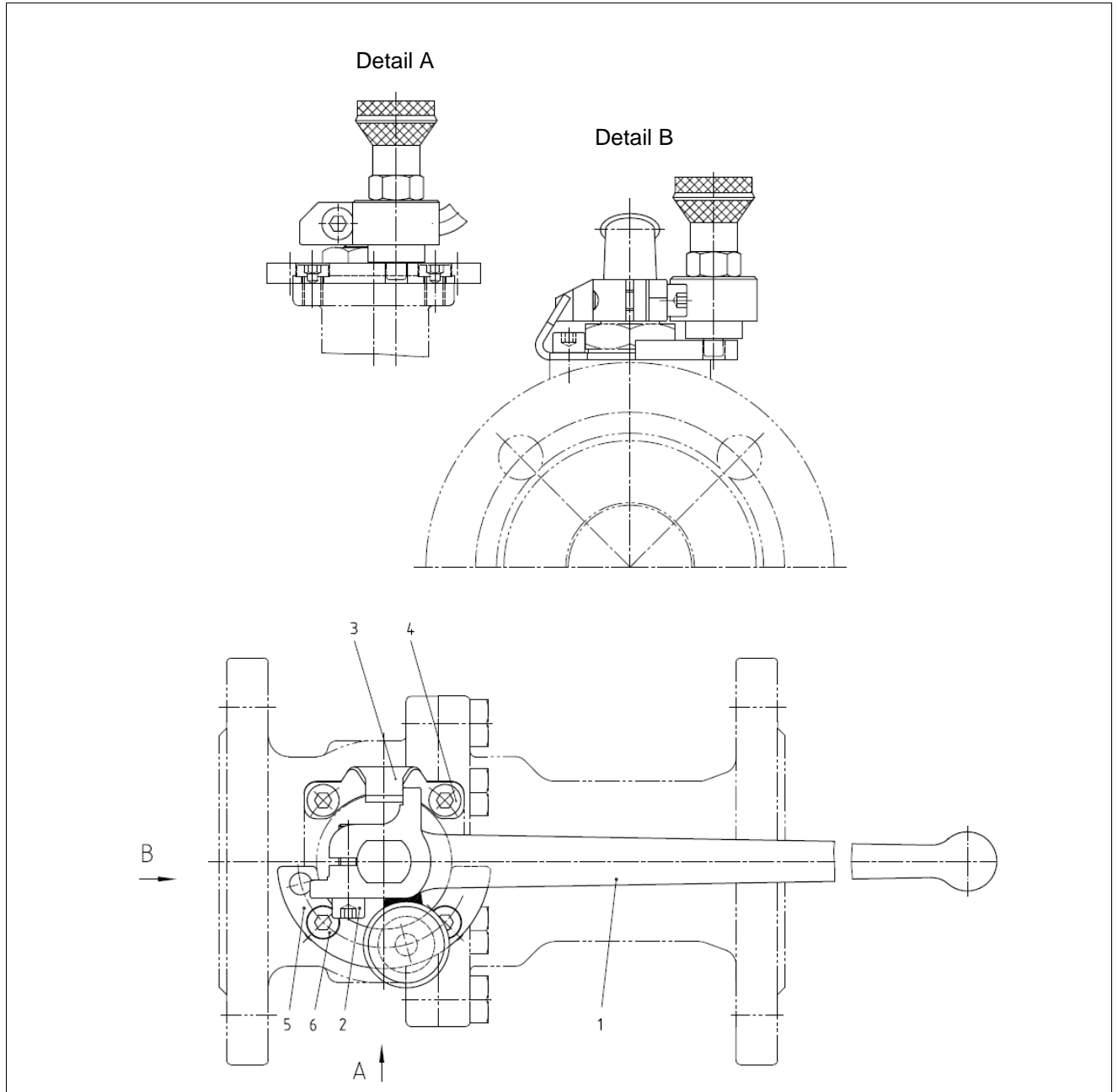

No.	Part	Material
1	lever with locking bolt	1.4408/A2-Nirosta
2	socket screw	A2-70
3	stopper	1.4301
4	socket screw	A2-70
5	base plate	1.4301
6	socket screw	A2-70

Subject to modification. 02/2018